

DIMENSIONS (mm/in.)

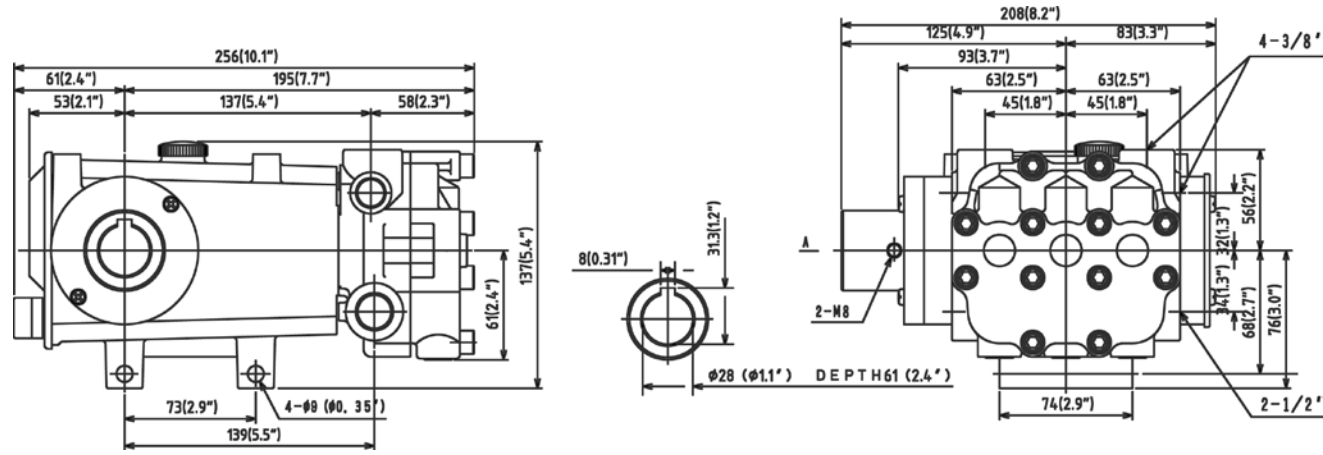

CUTAWAY

- 1 High strength, lightweight die cast crankcase
- 2 Oversized crankshaft bearings for long life and quiet operation
- 3 Forged crankshaft is machined for low friction, quiet operation and high efficiency
- 4 High strength connecting rods are tolerance matched for extended life and low friction operation
- 5 High polish stainless steel plunger rods for smooth operation and even wear
- 6 Zero clearance, polymer exclusionary seal protects pump crankcase from fluid entry and will not corrode
- 7 Proprietary blend, solid ceramic plungers for long wear and increased thermal shock resistance
- 8 Forged brass manifolds for strength and corrosion resistance, machined to optimize fluid flow and performance while extending useful life
- 9 Liquid-cooled, low drag seals provide long life, extended run-dry ability and increased suction lift
- 10 100% stainless steel valve construction provides superior protection against chemical and temperature damage
- 11 Mechanically-loaded seals require no adjustment and self-compensate for wear
- 12 Balanced flow crankcase ensures lubrication and quiet operation
- 13 Slide-in seal cases mean no special tools are required, making seal replacement easy

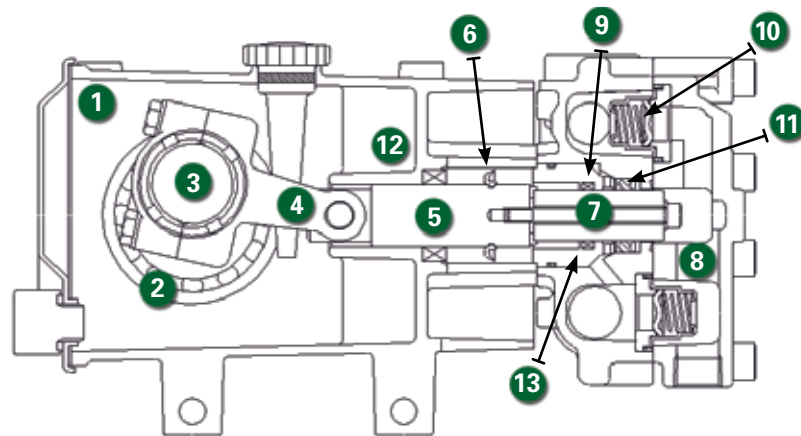

Floating 5 Series Model 521

FEATURES

- Unique mounting technology increases life and decreases noise (pat. pending)
- Triplex pumps provide smooth liquid flow
- Liquid cooled, low drag seals provide long life, improved suction, higher efficiency and longer dry running without damage
- Balanced flow crankcase design and precision machining ensures uniform lubrication and quiet operation
- Manifold is designed and machined to guarantee superior fluid flow
- Zero-clearance exclusionary seals protect crankcase

QUALITY

- 100% stainless steel valve assemblies deliver greater temperature and chemical handling abilities
- Precision ground ceramic plungers utilize a proprietary material blend for long life and increased thermal shock resistance
- Forged brass manifolds offer strength and corrosion resistance
- Proprietary, proven seal blend maximizes life and increases maintenance intervals
- Oversized crankshaft bearings for long life and quiet operation

MAINTENANCE

- No special tools required for repair or maintenance
- Fluid end is easily serviced without entering crankcase
- Easy access seal case and valve assemblies
- Seals require no adjustment

SPECIFICATIONS

Model 521	US	METRIC
Flow	4 gpm	15 lpm
Pressure	2500 psi	170 bar
RPM	1800	1800
Inlet Pressure	flooded to 70 psi	1 to 5 bar
Inlet	1/2" NPT	1/2" NPT
Outlet	3/8" NPT	3/8" NPT
Oil requirement	21 oz.	.61 L
Shaft Dia.	1.102"	28 mm
Max Liquid Temp.	170°F	85°C
Shaft Location	L or R	L or R
Weight	21 lbs.	9.5 kg

Determining Pump RPM	Rated GPM	=	"Desired" GPM
	Rated RPM	=	"Desired" RPM
Determining Required HP	GPM x PSI	=	Electric Brake H.P. Required
	1460	=	
Determining Motor Pulley Size	Motor Pulley OD	=	Pump Pulley OD
	Pump RPM	=	Motor RPM

Parts List

REF. #	PART NUMBER	PART NAME	MATERIAL	QTY
F01	0259001010	MANIFOLD, PORTED	BRASS	1
F05	0259001200	SEAL RETAINER	BRASS	3
F07	0259001280	BACKING RING	FP	3
F08	02590014K0	V-PACKING	NBR/TEXTILE	3
F09	0259001230	VACUUM SEAL	NBR	3
F22	0259001430	SPREADER	BRASS	3
F23	0259001450	WAVE WASHER	STAINLESS	3
F25	9203B15032	O-RING, RETAINER	NBR	3
F30	0361001140	BOLT, MANIFOLD	PLATED STEEL	8
F34	0259003200	MANIFOLD, VALVES	BRASS	1
F40	0258103300	VALVE ASSEMBLY	STAINLESS	6
F42	0362003340	GASKET	NBR	3
F48	9203F10020	O-RING, MANIFOLD	NBR	3
F77	0180503450	PLUG, MANIFOLD	BRASS	3
P01	02560011001	BOLT, HEAD	PLATED STEEL	4
P05	0277902010	CRANKCASE	ALUMINUM	1
P07	02560020401	COVER	PLATED STEEL	1
P08	0256002050	GASKET	BONDED PAPER	1
P09	9138A050515	SCREW	PLATED STEEL	6
P10	0361001110	DOWEL PIN, MANIFOLD	STEEL	2
P11	9110B05020	BOLT	STEEL	4
P25	0090002320	DRAIN PLUG	FP	1
P26	0090002340	GASKET	NBR	1
P29	01300026000A	OIL DIPSTICK ASSEMBLY	FP	1
P31	9201B20016	O-RING, DIPSTICK	NBR	1
P37	0276101730	WATER SLINGER	NBR/FP	3
P40	0256302400	OIL SEAL	NBR	3
P50	0275504010	CRANKSHAFT	STEEL	1
P51	0256004020	BEARING	STEEL	1
P53	0256004030	OIL SEAL, SHAFT	NBR	1
P54	0256104430	OIL SEAL, BEARING	NBR	1
P56	0130004600	CON-ROD ASSEMBLY	ALUM/STEEL	3
P61	0276104880	ROD	STAINLESS	3
P63	0259024850	SPACER	BRASS	3
P64	0121114852	GASKET	COPPER	3
P65	0150004900	PIN, PLUNGER	STEEL	3
P66	9120R05060	BOLT, PLUNGER	STAINLESS	3
P70	02560044201	COVER, BEARING	PLATED STEEL	1
P71	0275504020	BEARING, ROLLER	STEEL	1
P71	02755044201	COVER, BEARING	ALUMINUM	1
P73	9203B15056	O-RING, COVER	NBR	1

* Material listed may be a proprietary version. Parts names without part numbers are only available within complete assemblies.

* Material codes: FP=Flouropolymer, NBR=Medium Nitrile (Buna-N), STAINLESS=Stainless Steel (300 Series)

Exploded View

Model 521

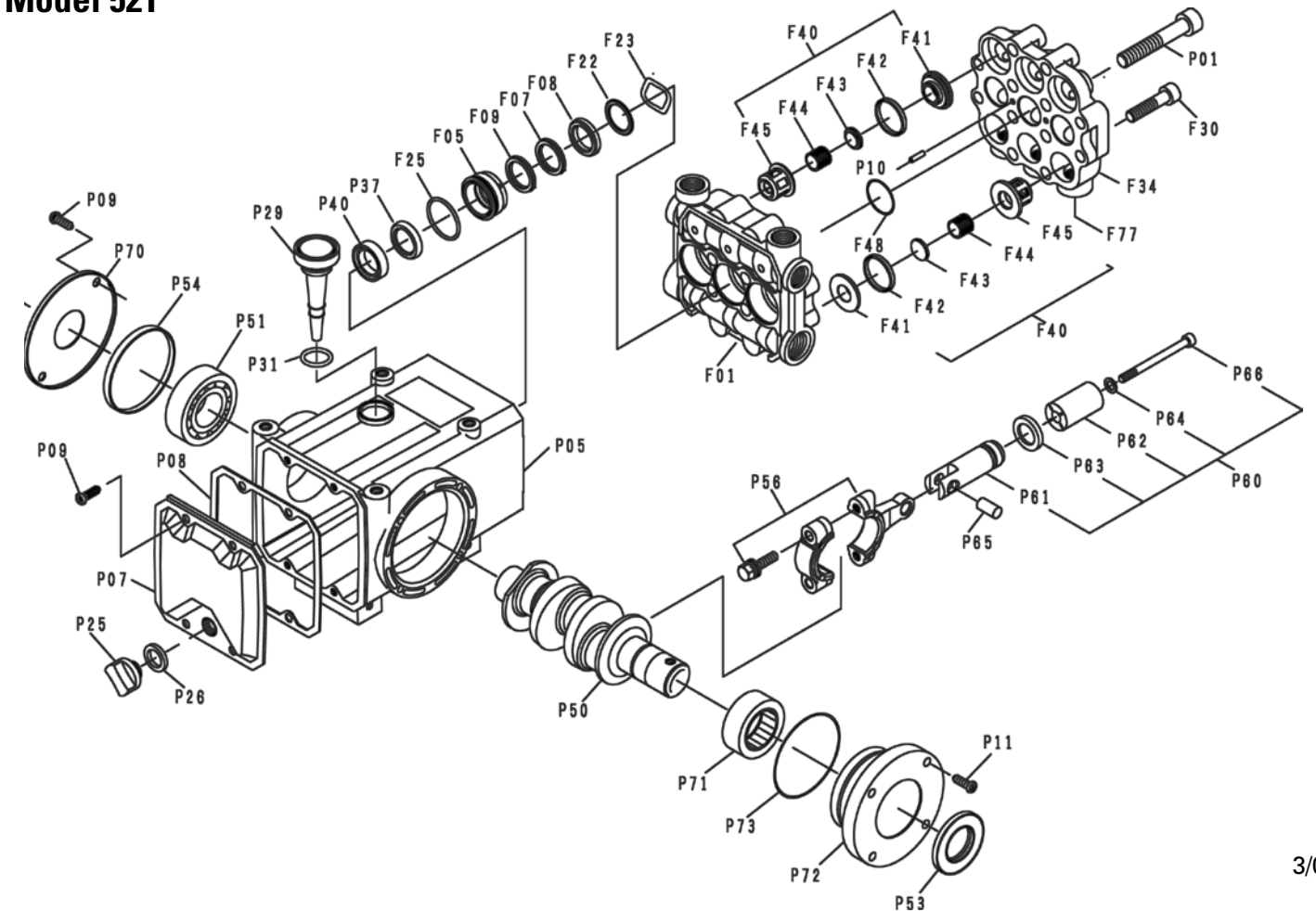

3/07

REF. #	PART NUMBER	PART NAME	MATERIAL	QTY
	30127	SEAL KIT, (INCLUDES F07, F08, F09, F25)	NBR	1
	30101	VALVE KIT, INLET (F40, F42)	STAINLESS/NBR	1
	30103	OIL, BOTTLE, 32oz., ISO 100		1
	30326	BRACKET KIT, FLOATING	COATED STEEL	1
Recommended Accessories				
	70200	REGULATOR, 5 gpm, 1200 PSI	BRASS	1

Horsepower Requirements

	Pressure (psi)							
	RPM	GPM	LPM	1000	1200	1500	2000	2500
521	600	1.3	5.1	0.9	1.1	1.3	1.8	2.2
	1200	2.7	10.1	1.8	2.1	2.7	3.6	4.5
	1800	4.0	15.2	2.7	3.2	4.0	5.4	